

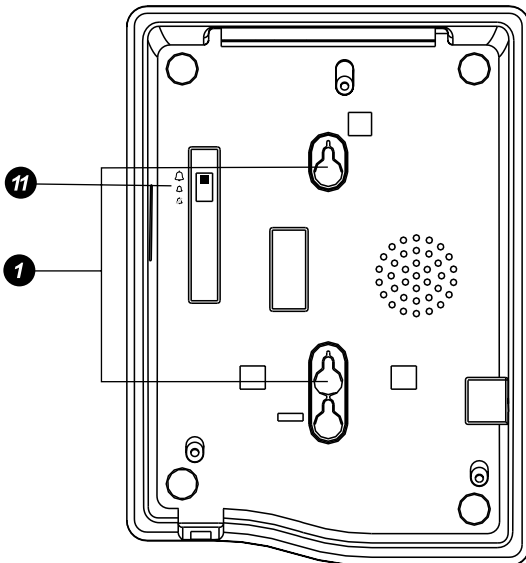

***SpliceCom PCS 5***

***Operating Instructions & User Guide***

**Figure One**

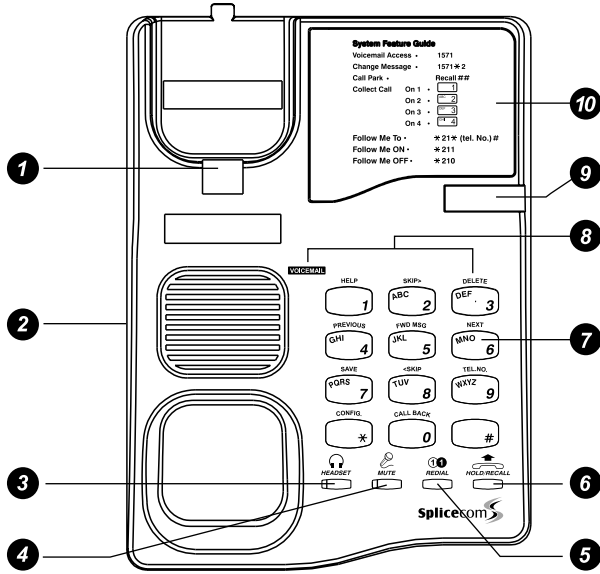

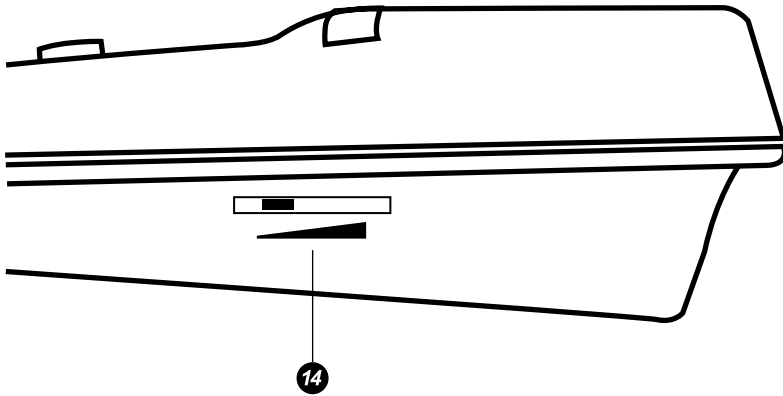
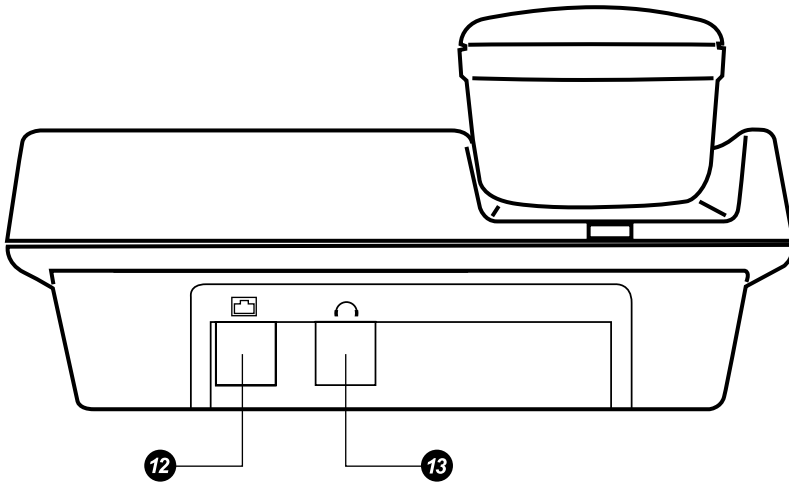





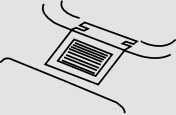
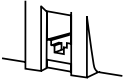

The SpliceCom PCS 5 telephone has been designed for use with the SpliceCom **maximiser** business telephone system.

## Telephone Features

Please refer to **Figure One** at the front of this user guide.

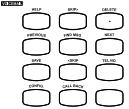
<b>1</b>		Wall mounting – Using the template supplied, position where you want to fix your telephone. Drill two holes and fix roundhead screws, slide the telephone into place. Remove the handset retainer by pushing up out of the slot. Turn the retainer through 180° and place back in its slot.
<b>2</b>		The handset cord plugs in here.
<b>3</b>		With headset connected to headset port, press this Headset key, wait for the dial tone and then dial in the number required.
<b>4</b>		This key mutes the microphone so the other person on the call cannot hear you. A red lamp indicates the mute is on. Pressing it a second time releases the mute and returns you to normal conversation.
<b>5</b>		Press this key to redial the last number you dialed from the keypad or insert a pause.
<b>6</b>		Press this key during a call to place it on hold. This will enable you to transfer the call to another party.
<b>7</b>		A standard telephone keypad with the number “5” having a raised dot for visually impaired users.
<b>8</b>		Integrated Voicemail Management allows you to easily manage the contents of your voicemail box.

9



The red call indicator light flashes when your telephone rings.

10

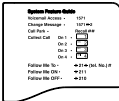

You'll find a list of the access codes for the ten most commonly used system features here.

11



A 3-position switch to control the volume of the ring tone. Select from loud ring, quiet ring or ringer off.

12



This jack is used to connect a line cord to your telephone.

13



This jack is used to connect a Headset to your telephone.

14



To adjust Headset volume

### ***Declaration of Conformity***

**SpliceCom declares that this product SpliceCom PCS 5 is in conformity with the following harmonised standards:**

**Health Safety**

**EN 60950 : 1992**

**Electromagnetic Compatibility**

**EN 55022 : 1998 & EN 55024 : 1998**

**Telecom**

**TBR21 : 1998 & TBR38 : 1998**

**Following the provisions of the Council Directive on radio and telecommunications terminal equipment.**

**October 2004.**

## ***Intended Use***

The SpliceCom PCS 5 telephone supports Touch-Tone Dialling (DTMF) only. This telephone also supports Timed-break recall, no special settings are needed to engage these features.

The telephone has been designed for use with the SpliceCom **maximiser** business telephone system.

Because the product is connected behind a PABX it must not be relied upon to contact the emergency services during a power failure.

The following section explains how to use your SpliceCom PCS 5 with the SpliceCom **maximiser** business telephone system.

## ***Basics***

**To make a call (Handset/Headset operation):** To dial a number, either lift the Handset or press Headset button, wait for the dial tone and then dial in the number required e.g. 02087654321 - there is no need to dial a 9 prefix but if you do, the call will still get through. Both 999 and 9999 will call the emergency services.

The headset button has auto-detection function. When the headset is connected, the handset function is disable. Unplug the headset to revert to handset mode (even during a call).

**Holding a call:** Press the “recall” button (6) on the PCS 5. You will hear dial tone the other end will hear a hold message/music (for external calls) or a comfort tone/beep (for internal calls). The call will remain on hold until you press “recall” again, or hang up.

**Transferring a call:** Answer the call, then press “recall” – you should hear the dial tone. Dial the internal/external number required.

If you hear ringing you can then replace your handset and the caller will be immediately connected to the destination – this is known as blind transfer.

OR – For an announced transfer.

You hear ringing and wait till the destination answers.

If the destination is willing to take the call – replace the handset to complete the transfer.

If the destination is unwilling to take the call – press “recall” to clear that call and talk to the caller again. You will be returned to the original caller if/when the destination hangs up.

**Call Waiting:** During a call you hear a beep in your ear – this indicates you have another call waiting. If you ignore it, the beep will repeat every few seconds for 20 seconds.

You can press “recall” to put the original caller on hold and talk to the new call. Once you have finished, you can press “recall” to clear the call and return to the original call.  
OR

Conclude the original call and put the handset down, the original call will clear and the new one will ring.

**System Feature Access Guide:** The following maximiser system features can be accessed by using the telephone keypad of your PCS 5.

- Voicemail Access – Dial “1571”
- Change your Voicemail Greeting – Dial “\* 2” once you’ve accessed your Voicemail box.
- Call Park – Dial “Recall# #” to park a call. You will be notified which park slot it has been placed in.
- Park 1 Collect – Dial “1” to collect a call parked in park slot 1
- Park 2 Collect – Dial “2” to collect a call parked in park slot 2
- Park 3 Collect – Dial “3” to collect a call parked in park slot 3
- Park 4 Collect – Dial “4” to collect a call parked in park slot 4
- Follow Me To..... – Dial “\* 21\* 02081234567#” to use 02081234567 as the number to forward your calls to.

- Follow Me ON – Dial “\* 211” to enable your calls to be forwarded to the telephone number you’ve set in Follow Me To.
- Follow Me OFF – Dial “\* 210” to turn off the Follow Me feature.

**Voicemail:** SpliceCom’s maximiser business telephone system features integrated voicemail, which is available to answer your telephone when you are busy or unavailable. Typically your voicemail will answer any call that has rung for 20 seconds.

**Using Voicemail:** To check or listen to your messages dial 1571 – messages are then played in the order recorded. Messages are stored until you listen to them. Once you have listened to a message it is automatically deleted after 3 days, unless you choose to save it. While listening to a message you can press “3” to delete it. A message is marked as heard once you have listened to the first 10 seconds. The integrated Voicemail Management Guide **8** will enable you to manage your Voicemail messages effectively.

**Leaving a message for a colleague:** After dialling their extension and being transferred to voicemail, press # to cut the greeting and start recording. Press 0 during the greeting/recording to be transferred to reception or a nominated departmental/personal alternative (if configured).

**Collecting a message:** Messages can be collected by; dialling 1571 from your PCS 5, dialling a general number configured by your administrator, dialling the external DDI number for the Voicemail, or dialling your extension number, then pressing \* during the greeting. Dependent on your system configuration, you may be prompted for an account (extension) number and/or access code (pin/password). The voicemail will then automatically play your new messages in time order and then any old messages.

**Navigation:** You can navigate you way through messages if required by pressing buttons on the PCS keypad. It is probably easier to remember them by referring to the chart below which is also provided on the PCS 5 keypad:



### 5 - Forwarding options:

- 1 – Copy to another voicemail user with a message from you
- 2 – Copy to another mailbox
- 3 – Copy to your email address
- 0 – Abandon

### \* - Configuration options:

- 1 – Play help
- 2 – Record a new greeting
  - 1 – Options
  - 2 – Record a new greeting
  - 3 – Delete any new recording or restore default greeting
- 7 – Save new greeting (hanging up will do the same)
- 0 – Abandon

3 – Set forwarding

1 – Options

2 – Cancel forwarding

3 – Forward personal/direct calls to home number

4 – Forward personal/direct calls to mobile number

5 – Forward personal/direct calls to spare1 number

6 – Forward personal/direct calls to spare2 number

7 – Forward personal/direct calls to your current number

0 – Abandon

4 – Add a voice tag/name to number (which will then be played immediately before messages)

1 – Options

2 – Record new tag

3 – Delete tag

7 – Save tag

0 – Abandon

**PCS 50 and PCS 5:** Even greater personal productivity can be realised when you partner your PCS 5 phone with SpliceCom's PCS 50 application. This desktop productivity application delivers all of the functionality associated with the top of the range PCS 400 and is available for Windows, Mac OS X and Linux PCs and laptops. Some of the extra features you can gain access to when using the PCS 50 in conjunction with the PCS 5 include;

- Caller Display
- Access to company wide, Contact, User and Departmental directories
- A Personal Favourite/Speed Dials/Direct Station Select/Busy Lamp Field area
- Last Number Redial and Incoming/Missed Call Lists
- Visual Call Pickup

- Visual Message Box Management
- Visual Park Slots
- Conference Calls
- Personal Call Recording
- Integrating your PCS 5 with the company Intranet or Web-enabled applications

For further details on installing the PCS 50 and how to use it in conjunction with your PCS 5 please see SpliceCom's User Guide for the PCS 400, PCS 200 & PCS 50.

### ***Warranty Terms & Service>Returns Procedure***

This product is guaranteed for six years from the date of manufacture in the UK only and for 18 months in all other territories. You will find the manufacturing date on a label affixed to the underside of the phone in the format; MFG: DD/MM/YY.

A warranty is designed to cover either manufacturing faults or component defects. It is not designed to cover fair wear and tear – the Handset Cord and Line Cord are NOT covered by this guarantee. The warranty is no exception.

We look to you, our customer, to be reasonable and sensible over the warranty. We will endeavour to repair any telephone returned within the warranty period, but we reserve the right to charge for items that we consider replaceable under wear and tear. The Handset Cord and Line Cord are not covered by this guarantee, if a Handset Cord splits within a few months it will be replaced. If a phone is returned after, say, four years of heavy use with a similar problem we may take a different view and wish to charge.

If you have a genuine warranty problem and provided that the warranty seal has not been broken, your phone will be repaired, or, at our sole discretion, replaced, with a similar telephone. In the event that a model may have been discontinued, any replacement will have similar or enhanced features.

In the event that you have to return a faulty unit, please contact the Accredited SpliceCom reseller you purchased your PCS 5 from.

This warranty is in addition to any statutory rights.



This telephone is approved to EEC directive 1999/5/EC



SpliceCom Limited  
The Hall Business Centre, Berry Lane  
Chorleywood, Hertfordshire, WD3 5EX

Tel:01923 287700

Fax:01923 287722

Email:info@splicecom.com

Website:www.splicecom.com

3C9330011RSP